

### Content

Screws 23mm  
(The number varies depending on the size of the side)

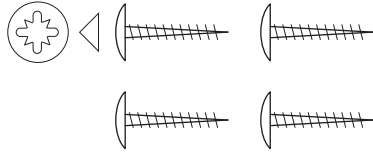

3M wet wipe



MountPads 40x25mm

(The number varies depending on the size of the side)



### Finished result

The result varies depending on the size of the frame.

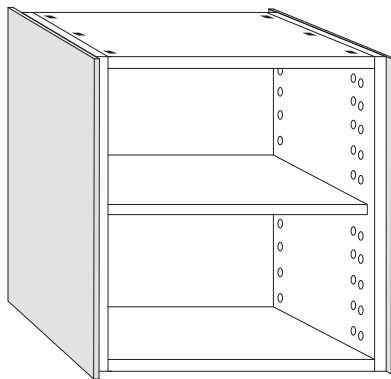

FRONT VIEW

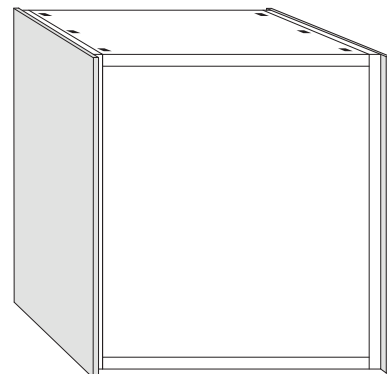

BACK VIEW

### Mounting

#### 1. Mount the wall brackets on the cabinet.

Mount the wall brackets supplied by Ikea on the back of the frame before mounting the Superfront sides. This is important so that the sides end up in the right place on the cabinet.

#### 2. Clean the surfaces.

Use the attached 3M wet wipe to clean the surfaces of the cabinet side and the Superfront sides. If you are going to mount a Superfront top, be sure to wipe off these surfaces as well.

#### 3. Attach the MountPads on the frame.

Place the frame on a hard, flat surface with the backside down. Attach the MountPads on the sides of the frame according to the picture on the back page. If you are going to mount a Superfront top as well, now also mount the MountPads supplied with the top.

**NOTE!** Do not remove the cover paper from the MountPads yet!

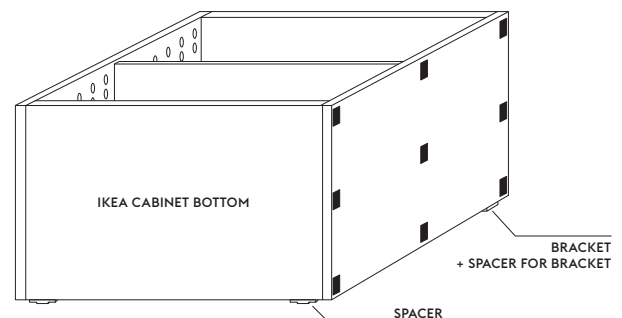

Continued on back page ►

### Safety!

Be sure to always follow the safety instructions that apply to your furniture. Always secure the cabinet to the wall. This also applies to low cabinets where the weight distribution changes drastically when the fronts open. Especially in the case of solid quality fronts as ours. Use the anchor brackets supplied with the Ikea cabinet.

### Distribution of MountPads.

Here's how the MountPads should be distributed on the side of the cabinet frame.

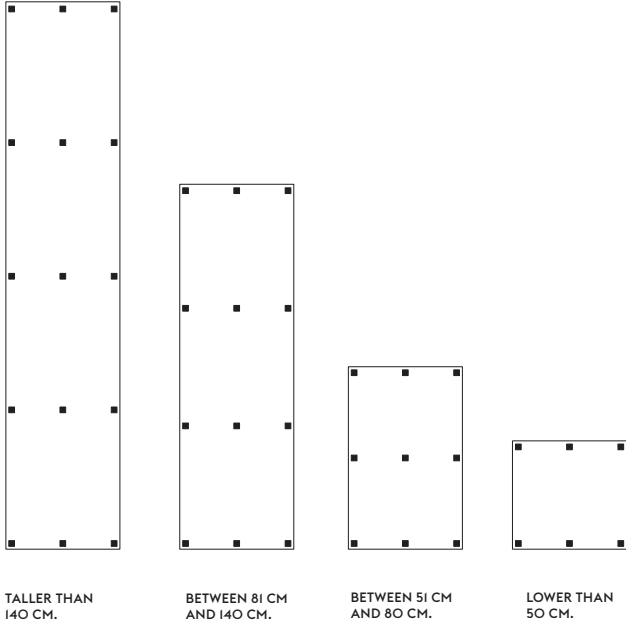

### 4. Place support at the top of the frame.

Place a shelf or a similar flat surface along the cabinet top. Ask someone for help to make sure that the surface is held tight against the top. This support is for the side to end up exactly at the height of the top of the frame.

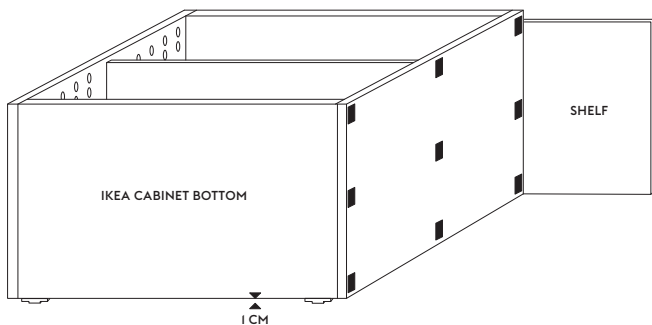

### 5. Tilt the side in place and PRESS.

Do this step first without removing the cover paper on the MountPads so that you get the hang of it before you do it for real.

Place the side as shown below. Be sure to keep the side tight against the shelf at the top. Slowly tilt the side upward until it touches the MountPads. Note that, due to the wall brackets, the frame is about 1 cm above the floor, but that the side should stand on the floor when it is tilted up so that it reaches all the way to the wall when the cabinet is put in place. Make sure that it ends up in the right position.

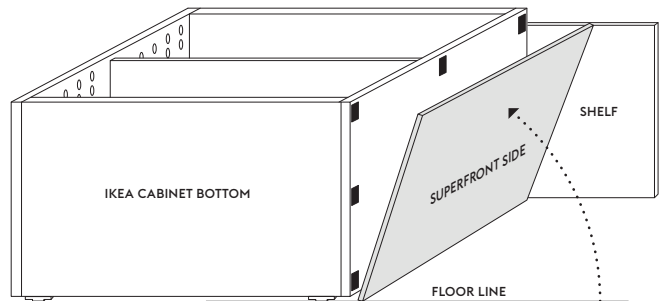

**PRESS HARD OVER EACH MOUNTPAD FOR AT LEAST 30 SECONDS.** This is important because the adhesive in our MountPads cure under pressure.

### 6. Drive the screws.

These screws work as additional support. Press on the outside of the side at the point where you drive the screw. Spread the screws as evenly as possible without them being in the way of the hinges or shelf supports.

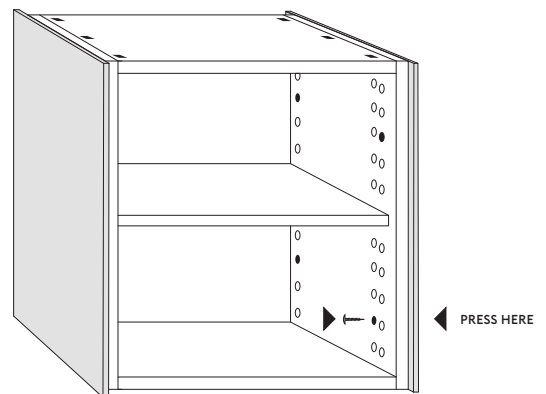

### Safety!

Be sure to always follow the safety instructions that apply to your furniture. Always secure the cabinet to the wall. This also applies to low cabinets where the weight distribution changes drastically when the fronts open. Especially in the case of solid quality fronts as ours. Use the anchor brackets supplied with the Ikea cabinet.